

DESCRIPTION

The PCS retrofit kit replaces both PCS1 and PCS2 controllers in PCS 1/2 controlled Power Systems (PPS16 and Forza) with no need to use a PNI card/box for Ethernet communication.

The retrofit kit is based on ACC Extended (ACX) hardware but uses different firmware to keep PCS1/2 functionality, which allows users to keep the existing configuration for system and battery management.

System control is interfaced through the PCS Interface cards and implementation into existing systems is simplified by door/panel replacement and little work on signal cabling.

FEATURES

- ◆ User-selectable alarm parameters
- ◆ Password controlled environment
- ◆ USB or RS232* Interface
- ◆ Programmable alarm routing
- ◆ 100 Mbps Ethernet interface + web server support + SNMPv1,v2,v3
- ◆ 1000-event alarm log
- ◆ Audible Alarm
- ◆ Remote configuration upgrade
- ◆ Micro SD card data logging
- ◆ Multiple Language Support

SAFETY COMPLIANCE

UL60950-1 2nd Edition
 CSA22.2, No. 60950-1 2nd Edition
 EN60950-1 2nd Edition

www.unipowerco.com

North America & CALA: +1 954-346-2442 · EMEA: +1 561-990-3830 · sales@unipowerco.com



INTELLIGENT SITE MANAGEMENT

- ◆ Battery tests and log
- ◆ Battery voltage and symmetry monitoring
- ◆ Remaining battery capacity measurement
- ◆ Low Voltage Disconnect
- ◆ Temperature compensation with programmable compensation factor
- ◆ Monthly data logging
- ◆ Site log tools

Ordering Guide

Description	Part Number
19" Kit	001-5295-1900
23" Kit	001-5295-2300
DC-DC Converter	100-4315-0000

See [application note](#) for guidance on which parts are required for the different applications.

WEB INTERFACE

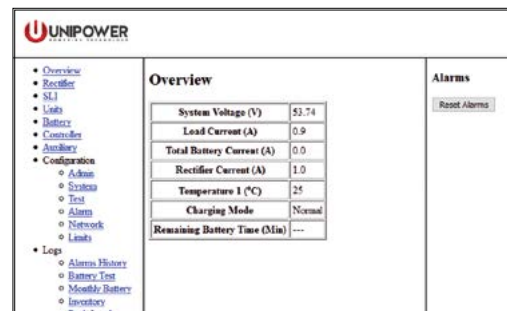

THREE YEAR WARRANTY

Input

Voltage	18 - 60VDC
Current	< 200mA

Interface

Display	3 x 16 character LCD
Language Support	English, German, Spanish, Russian, Chinese
Internal Communication	RS485 Data Bus (64 modules max.) microSD card (up to 4GB)
External Communication	USB or RS232* interface for remote control via modem or directly from a PC with PowCom™ software. Ethernet port allowing monitoring and control over a TCP/IP network. Web browser support + SNMPv1,v2,v3.
Indications	Green LED - Power ON Yellow LED - System warning Red LED - System alarm
Software	Site upgradeable by Flash memory

Alarms

Low System Voltage High System Voltage Load/Battery Disconnection Mains Error Distribution Fuse Failure Battery Failure Module Failure High Battery Temperature Symmetry Fault Battery Fuse Failure	High Load Battery Fuse Disconnected Urgent Module Failure Communication Failure Partial Load Disconnection Temperature Probe Failure High Distribution Load Alarms Are Blocked 16x User Defined Alarms
--	--

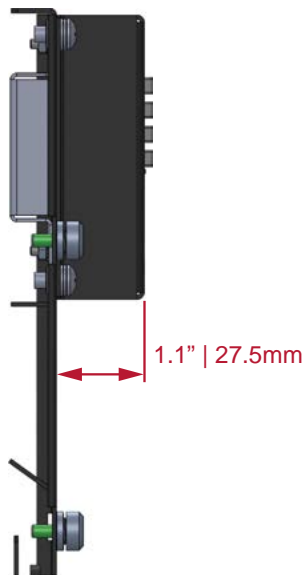

Other Technical Data

Dimensions	19" Panel - 19" x 2U H x 1.75" D 23" Door - 23" x 3U H x 1.75" D	
Weight	3.3-4 lbs 1.5-2kg	
Operating Temp.	-40 to +70°C	
Storage Temp.	-40 to +85°C	
Safety	IEC 60950-1, UL60950-1, & CSA-C22.2 No. 60950-1-03	
EMC	EN 61000-6-2, EN 61000-6-3, EN 300 386-2	
Environment	Storage: Transport: Operation:	ETS 300 019-2-1 ETS 300 019-2-2 ETS 300 019-2-3

Battery Management

Battery Disconnection	Allows voltage controlled disconnection of batteries.
Boost Charging	Manual time controlled or automatic boost charging with adjustable time and voltage levels.
Battery Tests	Automatic or manual testing of batteries up to six times per year with a 10 test memory. Variables include test duration and end voltage. Battery discontinuance test to ensure battery connection.
Enhanced Battery Monitoring	Monthly logging of essential battery parameters including temperature, temperature hours, current, charging voltage and symmetry voltage, Data logged for 5 years.
Site Logs	System tools developed to assist site management. Daily peak load and statistic logs available.
Symmetry Measurement	Optional tool that measures batteries for early detection of thermal runaway.
Temperature Compensation Charging	Allows continuous adjustment of output voltage according to battery temperature. Features include adjustable compensation factor and separate thresholds for high temperature alarms.
Load Shedding (PLD)	Optional feature that allows voltage or time controlled disconnection of non-essential load.